

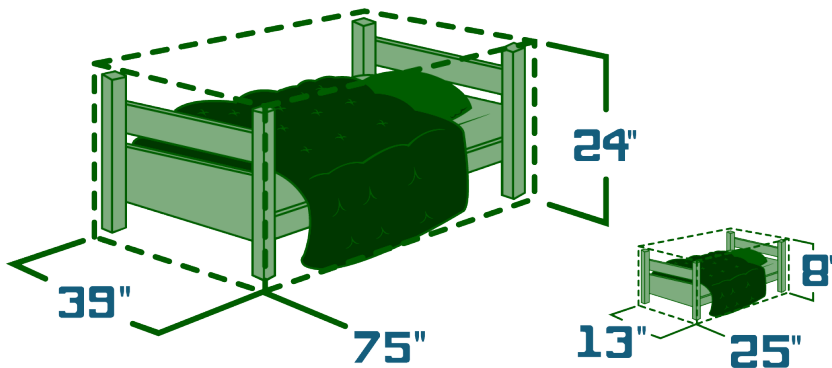

The *Scale Ella* animation is available on iTunes U (search "Math Snacks") and at [mathsnacks.org](http://mathsnacks.org)

The regular size of a twin bed is 39" wide, 75" long and 24" high. Scaleo has scaled your bed to this size: 13" wide, 25" long and 8" high.



**1. What can Scale Ella do so that you can sleep comfortably tonight?**

*Answers will vary, but should include some discussion about scaling the bed up or your height down.*

**2. Scaleo has now scaled you to be bigger by a scale factor of 7. What is your new height?**

$$\square \times 7 = \square$$

**Your Height x Scale Factor = Your New Height**

*Answer:  $\underline{\quad} \times 7 = \underline{\quad}$  Your Height x Scale Factor = Your New Height. (Answers will vary)*

**A. Will you fit on a regular-sized bed?**

*Answers will vary: If new height is greater than 75", the answer would be no, but if new height is less than 75", the answer would be yes.*

**B. If you can't, what can Scale Ella do to help you?**

*Answers will vary: Scale Ella can scale you down or scale the bed up; scale factors will vary, but final height should be less than 75", or the bed size should be larger than the student's height.*

3. You have been given Scale Ella's powers, but before you scale items you have to practice by scaling numbers. Pick a scale factor that will increase the numbers and enter it into box 1. Pick a scale factor that will decrease the numbers and enter it into box 2. Once you pick your scale factors, complete the table by applying the scale factors to increase and decrease the numbers.

	Scale Up By		Scale Down By	
Numbers	1	<input type="text"/>	2	<input type="text"/>
.05	<i>Answers will vary</i>		<i>Answers will vary</i>	
1/2	<i>Answers will vary</i>		<i>Answers will vary</i>	
7	<i>Answers will vary</i>		<i>Answers will vary</i>	
13	<i>Answers will vary</i>		<i>Answers will vary</i>	
25	<i>Answers will vary</i>		<i>Answers will vary</i>	
102	<i>Answers will vary</i>		<i>Answers will vary</i>	

*Note: Before having students do this problem, have a discussion with them about which scale factors SCALE UP and which scale factors SCALE DOWN. ( $sf > 1$  scale up and  $sf < 1$  scale down.)*

*Answers should be multiples of the numbers the students selected and the numbers from column 1 in the table. If students use division to scale the numbers down instead of using fractions or decimals, validate their thinking and have a discussion about various ways to scale down.*

4. If you could scale up three things in your life by a factor of 5, What would you scale up? Why?

*Answers will vary depending on student choices.*

5. If you could scale down three things in your life by a factor of  $\frac{1}{5}$ , What would you scale down? Why?

*Answers will vary depending on student choices.*

